

# Tour Contract

**General.** Upon full payment of the tour price by the participant, Image Tours, Inc., 2828 Kraft Ave. S.E., Grand Rapids, MI 49512-2076, Ph: 616/957-1010, Fax: 616/957-0103, hereinafter referred to as 'the Tour Operator', agrees to provide the services specified in this brochure, subject to the terms, conditions, and limitations contained in this contract. The participant agrees that if there are any corrections or changes, the correct information will prevail.

**Included.** Consult the [What's Included in Your Tour](#) on our website.

**Not Included.** Charges for passports, visas, inoculations, laundry, beverages (except coffee, tea, or milk with breakfast or when expressly specified), travel insurance, optional excursions, postage, telegrams, telephone calls and surcharges, any items of a personal nature, or any other items or services the inclusion of which has not been expressly specified in this brochure.

**Itinerary Deviations.** Due to special circumstances, including but not limited to holidays, special events, seasonal schedule changes, weather, traffic delays and itinerary adjustments, some sights and stores may have limited hours or may not be available. Under such circumstances or toward the improvement of the tour experience, the Tour Operator and tour manager reserve the right to make changes in the itinerary or sights, at their sole discretion.

**Reservations.** The Tour Operator requires a signed Reservation Application and deposit for each

participant within one week from the date you make your reservation. Take or mail your signed Reservation Application and a deposit of \$200 per person (plus insurance premium if you are purchasing travel insurance offered by the Tour Operator), or full payment if less than 75 days prior to departure, to the travel agency whose name and address appear on the Reservation Application.

**Final Payment** must be received by the Tour Operator at least 50 days prior to departure. **Please Note:**

- 1) The Tour Operator will not release Trip Documents for any participant for whom it has not received a signed Reservation Application and payment in full.
- 2) The Tour Operator requires 16 days to clear a regular check. Therefore, to expedite final payment and release documents, the Tour Operator recommends the use of wire transfer, cashier's check, or credit card. We accept Visa, MasterCard, or Discover.
- 3) In case of late payment, your travel agency may charge you for express mailing payments and documents.
- 4) Within 50 days prior to departure, the Tour Operator reserves the right to cancel a reservation for which it has not received final payment, or for which it receives a check that is returned to the Tour Operator due to insufficient funds, and cancellation penalties will apply.

**Price Changes.** Tour prices are based on tariffs, taxes and rates of exchange as they were known to the Tour Operator on the date of booking, and are subject to change, without prior notice. However, if the tour price increases by more than 6%, the participant(s) may, within seven (7) days from the date of notification of such increase, cancel with full refund.

**Price Guarantee.** If participant pays in full at the time of reservation, the Tour Operator gives an unconditional price guarantee.

**Cancellations.** The Tour Operator must receive a written notification of cancellation by mail or fax. Using the date such notification is received by the Tour Operator, the following cancellation penalties apply and will be retained by the Tour Operator:

- 1) More than 50 days prior to participant's scheduled departure date, \$200 per person.
- 2) From 49 days to 1 day prior to participant's scheduled departure date, provided all documents (including airline tickets and/or train tickets if applicable) are returned to and received by the Tour Operator prior to or within eight weeks after the cancelled departure date:
  - a) Without a medical statement, 50% of the 'land only' price plus the cost of the air transportation (the difference between the land only and the land and air inclusive price).
  - b) With a medical statement (see 'Medical Statement Requirements' in the next section), 30% of the 'land only' price plus any cancellation fees charged by the airlines.

**Note:** No refund will be sent until the Tour Operator receives the documents. If the Tour Operator receives documents and medical statements more than eight weeks after the cancelled departure date, additional penalties and service fees will apply, possibly resulting in no refund.

3) Scheduled departure date and after, no refund.

**Note:** No refund will be issued for any unused portions of a tour.

**Medical Statement Requirements.** The Tour Operator must receive the medical statement within eight weeks of the scheduled departure date. The medical statement must be on the letterhead of an attending licensed physician (M.D. or D.O.) to the effect that participant or participant's travel companion is unable to travel due to the sickness or death of the participant or participant's travel companion, or a member of participant's or travel companion's immediate family, namely, spouse, child, brother, sister, parent, in-law, grandparent, or grandchild. No refund will be sent until the Tour Operator has received this medical statement.

**Change Fees.** After the Tour Operator receives the deposit, all changes, including but not limited to departure/return date (when the tour date remains the same), departure/return city in U.S., arrival/return city in Europe, 'air and land' to 'land only' and vice versa, and spelling of participant's name, are subject to acceptance by the Tour Operator and may result in an increase in your tour price. Changes must be submitted by fax or mail, and if confirmed by the Tour Operator, the following change fees will apply: more than 90 days prior to departure, \$50 per person; from 90 days to 60 days prior to departure, \$100 per person. Less than 60 days prior to departure, all changes are considered a cancellation and re-booking and thus, are subject to the cancellation policies. **Note:** Tour changes (to a different tour date or itinerary), and name changes (substitutions) are always considered cancellations/new bookings and are subject to the cancellation policies for that tour.

**Insurance.** For your protection against cancellation penalties we highly recommend trip cancellation insurance. In case your health insurance does not cover you outside the United States, you may want to purchase travel accident and optional sickness coverage. We also recommend purchasing baggage insurance. Ask your travel agency for travel insurance options.

**Baggage.** As you prepare for your trip, baggage is one of your major concerns. Here is important information with regard to allowances, loss or damage, and insurance:

- 1) Allowances. Although the airlines may have more generous baggage allowances, and many people would like to bring a larger bag, the luggage allowances for our European motor coaches are as follows: Each participant on the tour is entitled to one suitcase and one carry-on bag. The suitcase cannot exceed 30" x 22" x 10" (excluding wheels and handles), and cannot exceed 50 lbs (23 kgs) in weight. The carry-on must fit in the space under your seat. This space measures 17" x 14" x 8". In addition, each participant may carry a coat over their arm, a camera or small purse over their shoulder, and a magazine or book in their hand. Participants may bring a camcorder, but, for their own travel comfort, we recommend taking it in place of a carry-on. Baggage space on the coach is limited, and with a full complement of passengers we cannot comfortably accommodate more baggage. In fairness to all passengers, our tour managers are under instruction to direct any participant with a suitcase exceeding 30" x 22" x 10" to purchase a replacement bag on Day 2 of the tour and to leave the oversized bag behind or ask the hotel to ship it back home, entirely at the participant's own expense. If, however, there is room on the motor coach for the oversized luggage, the tour manager, at his/her sole discretion, may allow the oversized luggage on the motor coach, in which case the tour participant must pay the equivalent of \$3 per day to the tour manager at the beginning of the tour. If overweight luggage is refused by the hotel porters and/or the drivers, the tour participant will be required to carry their own luggage between the motor coach and hotel room.
- 2) Loss or Damage. Baggage loss or damage sustained while in the custody of an airline, hotel, bus company, or transfer company is not the responsibility of the Tour Operator. Airline liability for passengers' baggage is clearly stated on the passenger contract included on all air tickets, or a statement can be found on file for inspection at the offices of the airline. The airline's liability shall in no event exceed the actual loss incurred by the passenger, subject to proof of the amount of the loss.
- 3) What to do in case of damage or loss by an airline. The participant must report the loss or damage immediately (while still at the airport) to the airline in question for two reasons: a) Most airlines require immediate claims or they will not accept them, and b) Insurance companies have the right to void any claim that is not reported immediately.
- 4) Baggage Insurance. We recommend that participants purchase baggage insurance. Many travel insurance programs include coverage for lost or damaged baggage. As you consider travel insurance, check if the policy includes baggage coverage.

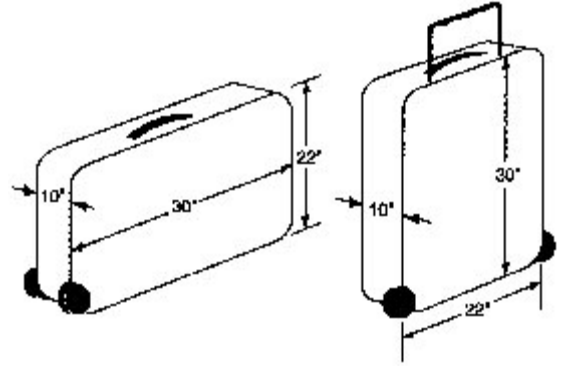

**Air Schedules.** The airlines and air schedules provided by the Tour Operator are subject to change at any time, and cancellation by tour participant due to airline or schedule changes will be subject to the cancellation penalties as outlined in the 'Cancellations' section above. Revisions requested by the tour participant will be noted, but under no circumstances will these requests be guaranteed, and the participant will be responsible for any price increases caused by such requests. If the tour participant does not like the air schedule, and wishes to get a more convenient schedule, he/she may ask their travel agent to check the cost and availability of a different air schedule/ airline, but must do so at least 90 days prior to departure. If the tour participant chooses another air schedule/airline, the tour participant will be charged the 'land

only' price by the Tour Operator and the airfare by the Travel Agent, and may not be eligible for airport transfers. If tickets are purchased by a source other than the Tour Operator, the Tour Operator shall not be held liable for any penalties incurred from the cancellation or change of the air ticket, for any reason. Therefore, we recommend tickets not be issued until 45 days or less prior to departure. Prices are based on Economy Class air space. Participants requesting to fly in the roomier Business Class should expect to pay at least \$2,500 additional per person.

**Responsibility of the Airlines.** The airlines are not held responsible for any acts, omissions, or events during the time the passengers are not on board their aircraft or conveyances. The passenger's contract in use by the airlines, when issued, shall constitute the sole contract between the airline and the passenger. Any and/or all transportation companies shall have or incur no responsibility for liability to any traveler aside from their liability as common carriers. Services performed and tickets issued by the air carrier are subject to rules and regulations relating to liabilities established by the Warsaw Convention and the terms and conditions of this contract.

**Cancellation by the Tour Operator.** The Tour Operator reserves the right to cancel a tour at any time for any reason, and its liability shall be limited to a refund in full of only those moneys it has received from or on behalf of the participant. If the participant has purchased the air ticket through any source other than the Tour Operator, it is his/her own responsibility to become familiar with the penalties and restrictions of the air ticket and, in the event of a cancellation or date change by the Tour Operator, the Tour Operator shall not be held liable for any penalties incurred from the cancellation or change of the air ticket. Therefore, we recommend tickets not be issued until 45 days or less prior to departure.

**Responsibility of the Tour Operator.** The Tour Operator shall be responsible for supplying the services and accommodations offered in this brochure as they relate to the land portion of the tour. If such services and accommodations cannot be supplied due to causes beyond its control, there shall be no responsibility or liability. In this event the Tour Operator will use its best efforts to supply comparable services and accommodations, and all travel arrangements may be subject to alteration or cancellation at any time with or without prior notice for any reasonable cause. Such alterations will not be considered cause for cancellation by the participant(s), and the usual penalties will apply. Nor shall the Tour Operator be liable for any injury, loss, damage, accident, delay, irregularity, or expense arising from strikes, war, terrorism, weather or other acts of God, quarantines, sickness, governmental restrictions or regulations, or from any act or omission of any individual, firm, or corporation furnishing sightseeing, hotel accommodations, or any other services in connection therewith, nor for any additional cost or expense due to disruption of advertised schedules, rates or services, or for any other cause beyond its control. The Tour Operator reserves the right to decline, to accept, or retain any person as a member of the tour at any time prior to departure, or in the course of the tour, should such participant's health, mental condition, physical infirmity, or general deportment impede, in the Tour Operator's judgment, the operation of the tour or the rights, welfare, or enjoyment of other tour participants, and all resulting costs will be the responsibility of the participant. The acceptance by the participant of any travel plan or other service shall be deemed to constitute acceptance of these limitations of liability or responsibility. No representative, employee, or agent of the Tour Operator is authorized to modify, waive, or in any way change the terms of this contract.

**Breach.** The Tour Operator and participant recognize and agree that a breach of this agreement by the other party will be actionable and will entitle either party to injunctive relief and other such equitable relief as deemed appropriate by the courts. The parties consent to the jurisdiction of the Courts of the State of Michigan, Kent County, in any such enforcement action, which will be governed by the laws of the State of Michigan.

**Entire Agreement.** Other than as stated herein, the participant warrants that no promises or inducements have been offered for this agreement other than as set forth herein and that this agreement is executed without reliance upon any other promises or representations.